

S Single Cavity Application

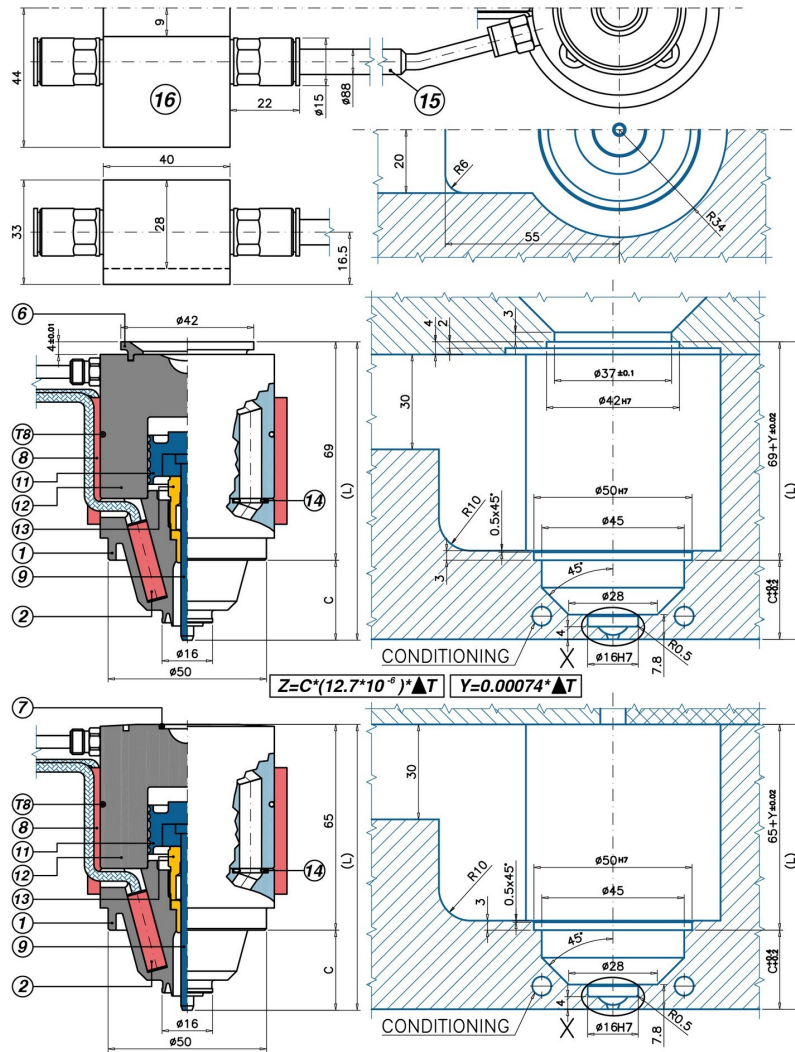

M MultiCavity Application

Code	C - L	1	2	6 - 7	8	T(8)	9	11	12
UGTL8001M	C=25 L=90	UGTL800C	0502KIT	UGACOR14	REPI55TL	S151551000J	UGTL800T	UGTL80P	UGTL80CTM
UGTL8001S	C=25 L=94	UGTL800C	0502KIT	UGTL80TT	REPI55TL	S151551000J	UGTL800T	UGTL80P	UGTL80CTS

INJECTION VESTIGE: T6 Direct injection nozzles for SINGLE and MULTI CAVITY applications, with needle valve activated by INNER PNEUMATIC PISTON. Suitable for: - making gate vestige nearly invisible - intense colours and colour change

- 1 = Nozzle body
- 2 = Cartridge heaters kit
n.2 without TC (0630026A0075X)
n.1 with TC (0630026B0080X)
- 6 = Centering Ring
- 7 = O-Ring
- 8 = PI model band heater
- T8 = Thermocouple J
- 9 = Needle Valve Ø 4

- 11 = Pneumatic Piston
- 12 = Needle Valve body
(M=MultiCavity / S=Single Cavity)
- 13 = Needle valve sealing
(UGTL04UGU-DLC + UGTL04BMT)
- 14 = O-Ring (N.1 UGACOR08)
- 15 = Connections+air pipes **(UGTL8RC)**
- 16 = Aluminium block **(UGTL8BL)**
- Ød = Standard 3,0 - on request: 1,5÷2,9

