

S Single Cavity Application

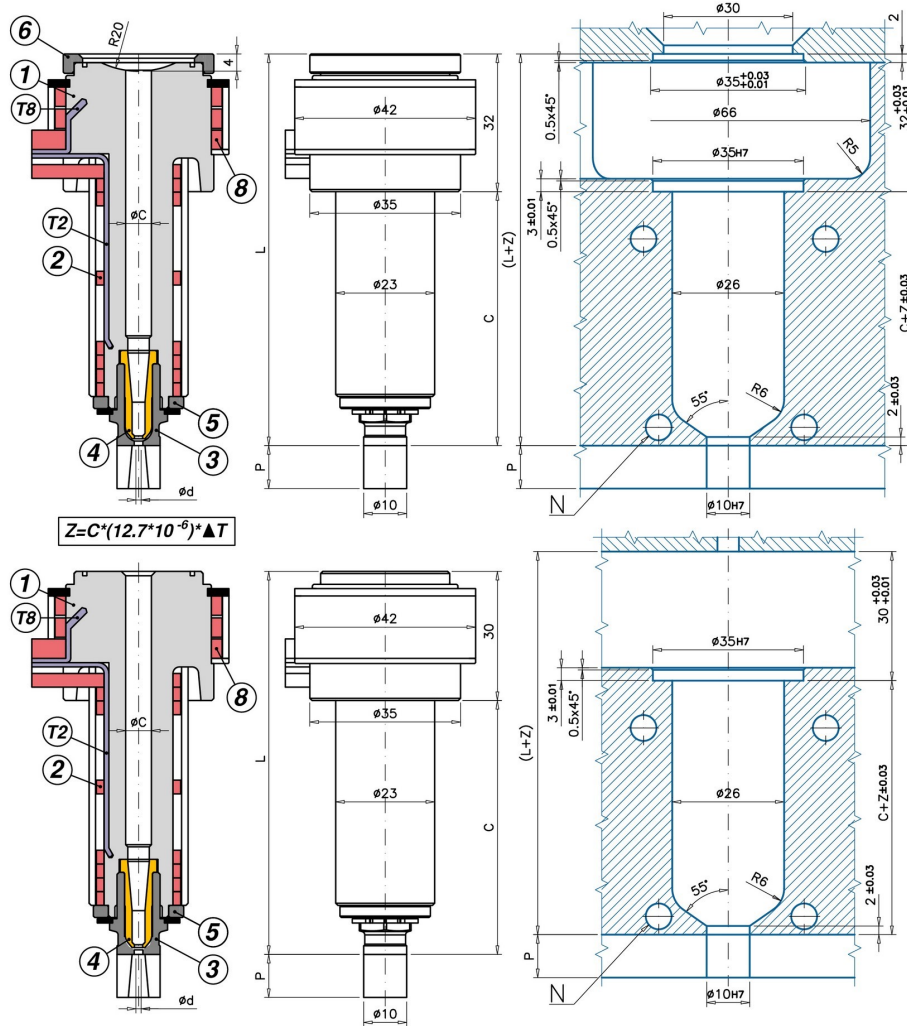

M MultiCavity Application

Code	C - L	1	2	T(2)	3 - 3/P	4/0 - 4/1	5	6			
UGER3651MA	-P 0/1	C=59 L=89	UGCR3501M	REPNSP3001	S151051000J	UGBC313	UGBC313P	UGPU325TZ	UGPU325CU	UGBE300AR	-
UGER3651SA	-P 0/1	C=59 L=91	UGCR3501S	REPNSP3001	S151051000J	UGBC313	UGBC313P	UGPU325TZ	UGPU325CU	UGBE300AR	UGAS3530
UGER3652MA	-P 0/1	C=89 L=119	UGCR3502M	REPNSP3002	S151551000J	UGBC313	UGBC313P	UGPU325TZ	UGPU325CU	UGBE300AR	-
UGER3652SA	-P 0/1	C=89 L=121	UGCR3502S	REPNSP3002	S151551000J	UGBC313	UGBC313P	UGPU325TZ	UGPU325CU	UGBE300AR	UGAS3530
UGER3653MA	-P 0/1	C=119 L=149	UGCR3503M	REPNSP3003	S151551000J	UGBC313	UGBC313P	UGPU325TZ	UGPU325CU	UGBE300AR	-
UGER3653SA	-P 0/1	C=119 L=151	UGCR3503S	REPNSP3003	S151551000J	UGBC313	UGBC313P	UGPU325TZ	UGPU325CU	UGBE300AR	UGAS3530
UGER3654MA	-P 0/1	C=159 L=189	UGCR3504M	REPNSP3004	S102051000J	UGBC313	UGBC313P	UGPU325TZ	UGPU325CU	UGBE300AR	-
UGER3654SA	-P 0/1	C=159 L=191	UGCR3504S	REPNSP3004	S102051000J	UGBC313	UGBC313P	UGPU325TZ	UGPU325CU	UGBE300AR	UGAS3530

INJECTION VESTIGE: T3B / T3BP NOZZLES WITH HEATED HEAD FOR DIRECT MOLDING ON PARTS WHERE IS NOT IMPORTANT THE AESTHETIC APPEARANCE OF THE INJECTION WITNESS (T3B), OR ON SPRUES (T3BP). - YES: frequent color change - YES: intense colours - YES: abrasive reinforcements (choose the 4/0 tip) - YES: SINGLE and MULTI-CAVITY applications - NO: plastics that leave stringings / droolings while mould opens

- 1 = Nozzle body
- (M=MultiCavity / S=Single Cavity)
- 2= Coil heater
- T(2) = J thermocouple
- 3 = Closed bushing
- (Ød = Standard: 1,0-1,2-1,5-2,0-2,5-3,0)
- 3/P = Bushing with machinable prolongation
- (Ød = Standard: 1,2-1,5-2,0-2,5-3,0)
- 4/0 = Abrasive charges tip
- 4/1 = Cu-Be tip
- 5 = Copper ring
- 6 = Centering ring

- 8 = Head nozzle coil heater (REPNS350)
- T(8)=Nozzle head J thermocouple (S151051000J)
- ØC = Standard: 6 - On request: 7
- P = Standard: 20 - On request: 0,5 ÷ 19.9
- O-RING on request

