

S Single Cavity Application

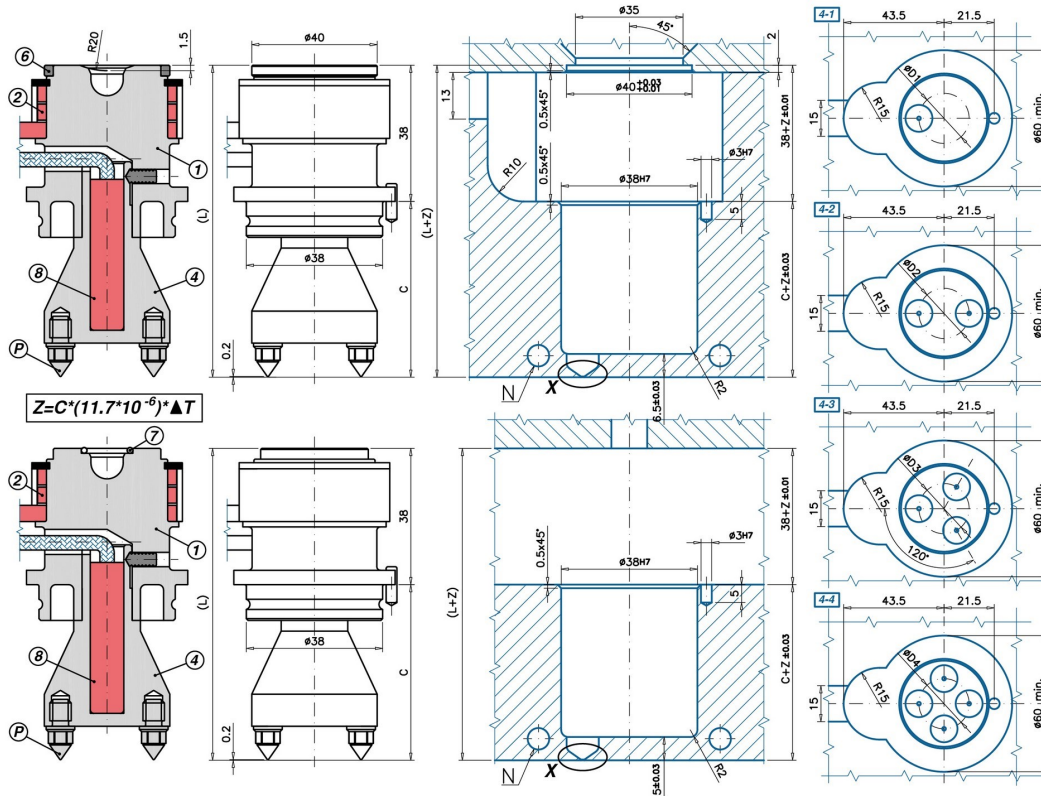

M MultiCavity Application

Code	C - L	1	2	4/0 - 1/2/3/4P	4/1 - 1/2/3/4P	6 - 7	8
UGGSA4510	1/2/3/4 M 0/1	C=49 L=87	UGCRG45M	REPTS350	UGPMA401 1/2/3/4	UGPMA411 1/2/3/4	UGACOR11 0950044B0300X
UGGSA4510	1/2/3/4 S 0/1	C=49 L=87	UGCRG45M	REPTS350	UGPMA401 1/2/3/4	UGPMA411 1/2/3/4	UGAS4030 0950044B0300X
UGGSA4520	1/2/3/4 M 0/1	C=61 L=99	UGCRG45M	REPTS350	UGPMA402 1/2/3/4	UGPMA412 1/2/3/4	UGACOR11 0950051B0300X
UGGSA4520	1/2/3/4 S 0/1	C=61 L=99	UGCRG45M	REPTS350	UGPMA402 1/2/3/4	UGPMA412 1/2/3/4	UGAS4030 0950051B0300X
UGGSA4530	1/2/3/4 M 0/1	C=73 L=111	UGCRG45M	REPTS350	UGPMA403 1/2/3/4	UGPMA413 1/2/3/4	UGACOR11 0950064B0350X
UGGSA4530	1/2/3/4 S 0/1	C=73 L=111	UGCRG45M	REPTS350	UGPMA403 1/2/3/4	UGPMA413 1/2/3/4	UGAS4030 0950064B0350X
UGGSA4540	1/2/3/4 M 0/1	C=85 L=123	UGCRG45M	REPTS350	UGPMA404 1/2/3/4	UGPMA414 1/2/3/4	UGACOR11 0950076B0400X
UGGSA4540	1/2/3/4 S 0/1	C=85 L=123	UGCRG45M	REPTS350	UGPMA404 1/2/3/4	UGPMA414 1/2/3/4	UGAS4030 0950076B0400X

INJECTION VESTIGE: T4V AXIALLY RANGED, MULTI-POINT SINGLE TORPEDO NOZZLES WITH HEATED HEAD - YES: injecting more parts with one only nozzle - YES: more than one gate vestige on the same part - YES: SINGLE AND MULTY-CAVITY applications - YES: abrasive reinforcements (choose the 4/0 tip) - NO: colour change

- 1 = Nozzle body
- (M=MultiCavity / S=Single Cavity)
- 2 = Coil heater with J-type thermocouple
- 4/0 = Tempered steel torpedo + No. 1/2/3/4 UGPUGSA4-0 abrasive charges tips
- 4/1 = Tempered steel torpedo + No. 1/2/3/4 UGPUGSA4-1 Cu-Be tips
- 6 = Centering Ring
- 7 = O-Ring
- 8 = Cartridge heater with J type TC
- S = Anti-rotation dowel pin

- Ød= Standard : 0,6 ÷ 1,0
- ØD1= 18÷25
- ØD2= 18÷25
- ØD3= 18÷25
- ØD4= 18÷25

