



HOT RUNNER INJECTION SYSTEMS

AUTOMOTIVE

EMP REF.: 20200683

TECHNICAL APPLICATION

FIELD: AUTOMOTIVE

MOULDED PARTS: Rail
Mounting

MOULDING MATERIAL: PP

GATES: 5

OPTIONS: PREWIRED SYSTEM

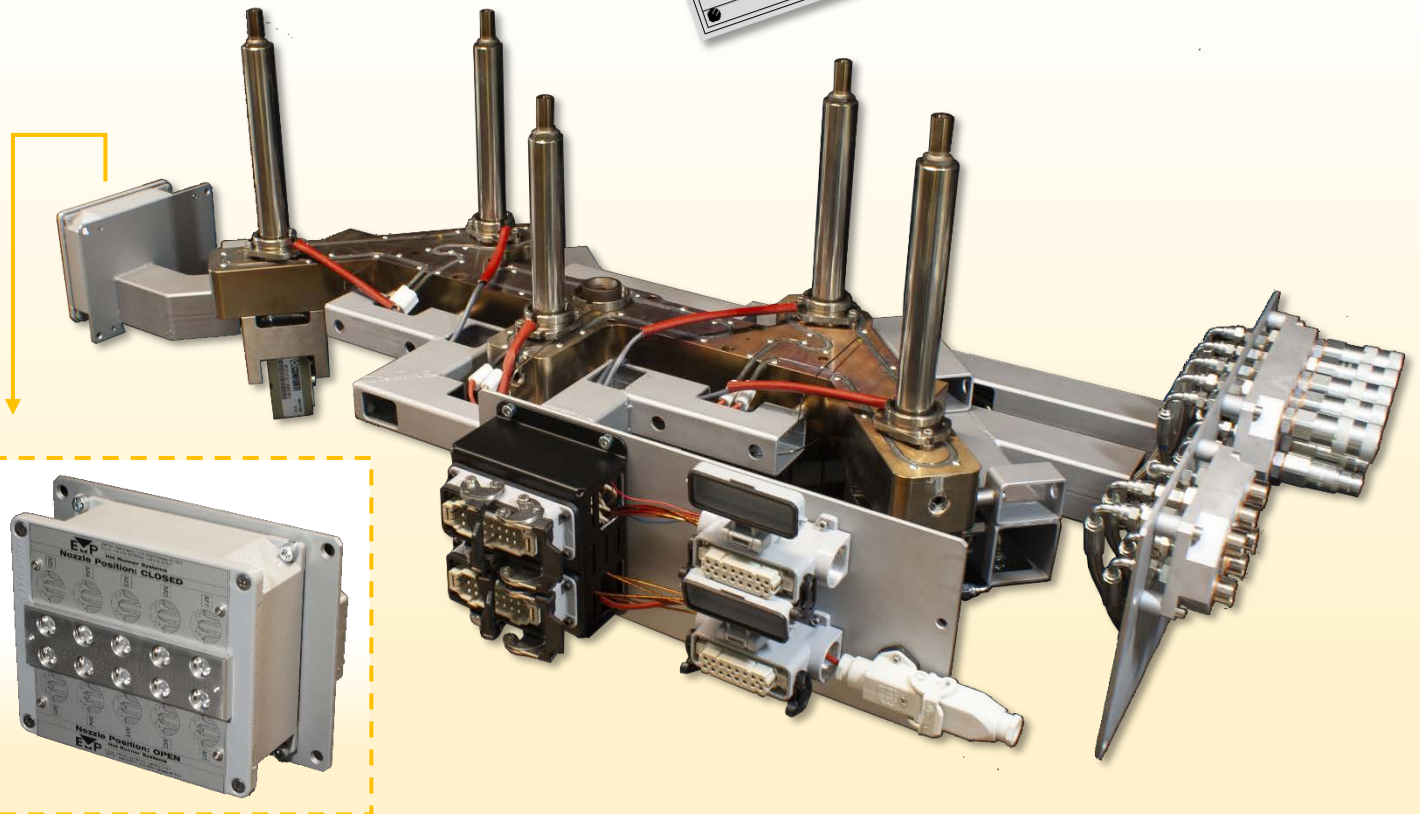
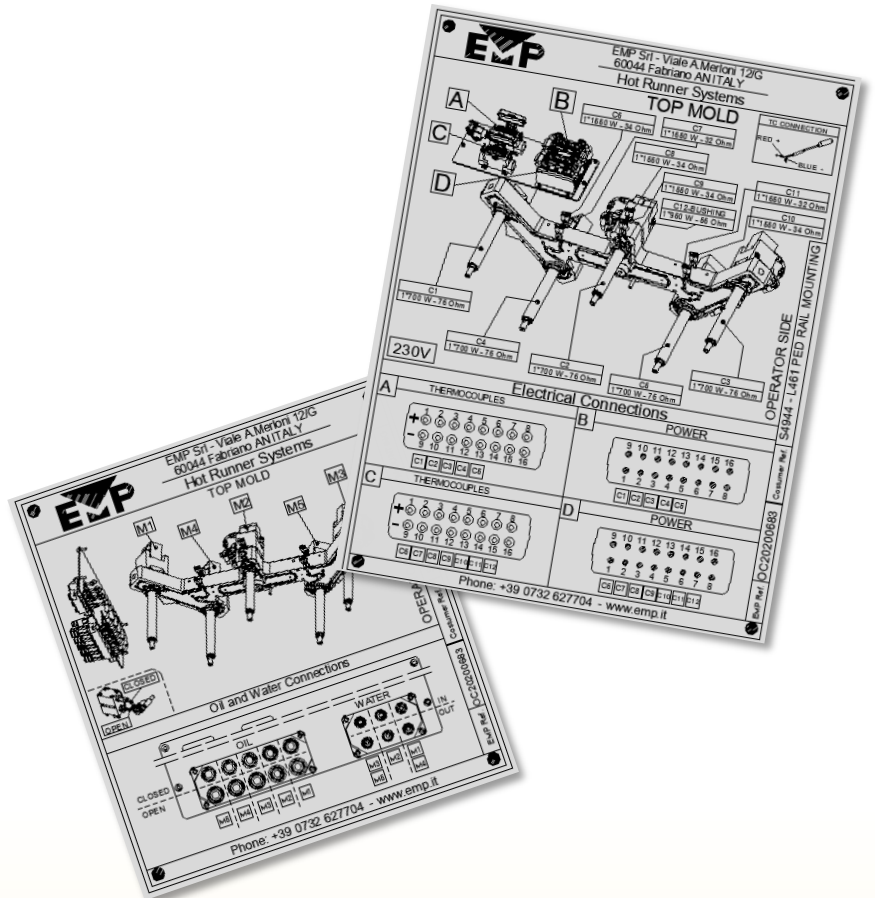
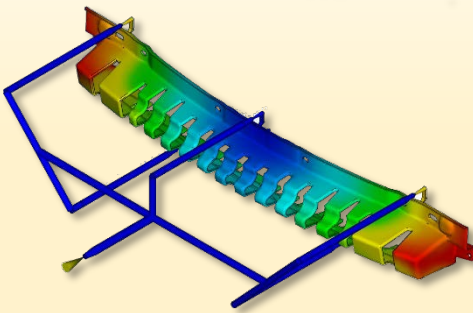

Viale A. Merloni, 12/G - 60044 FABRIANO AN - ITALY
Tel. +39 0732 627704 - e-mail: info@emp.it - website: www.emp.it





HOT RUNNER INJECTION SYSTEMS

EMP REF.: 20180110

TECHNICAL APPLICATION

FIELD: Automotive

MOULDED PARTS: L550 20MY
Close Out Panel

MOULDING MATERIAL: PP TD20

GATES: 3 Drop Sequential Valve
Gates onto Cold Runners

OPTIONS: Prewired system

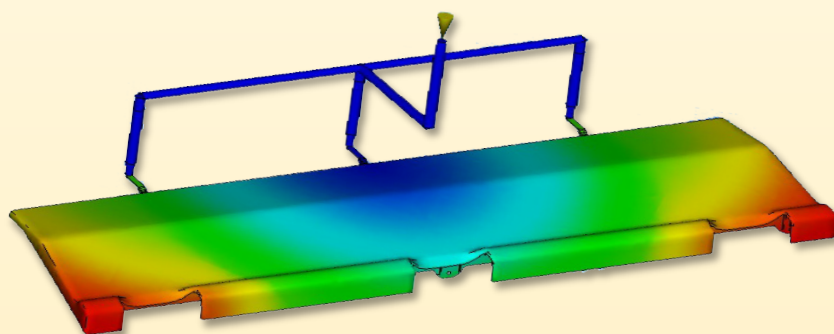
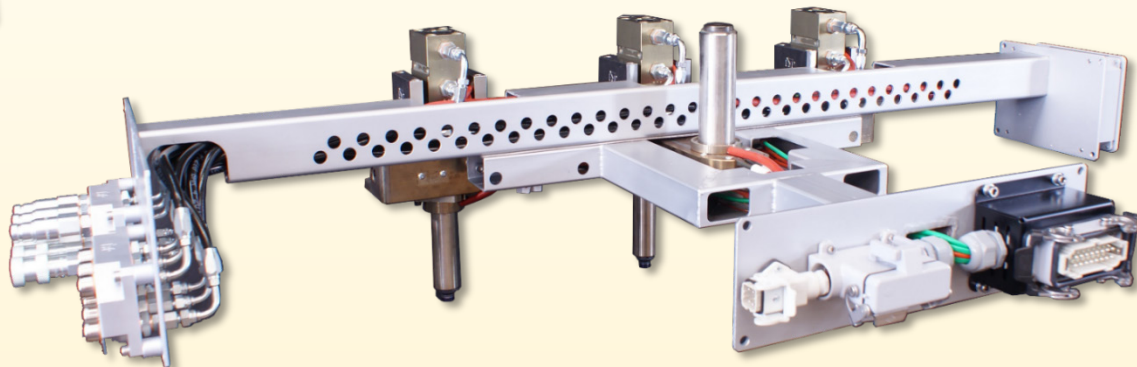
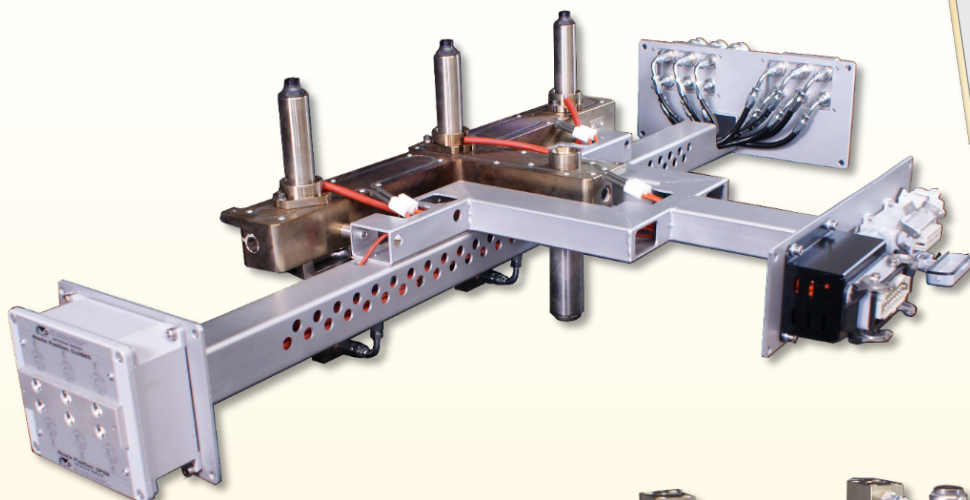
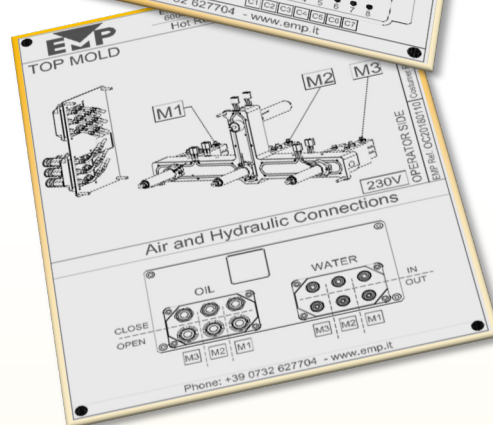
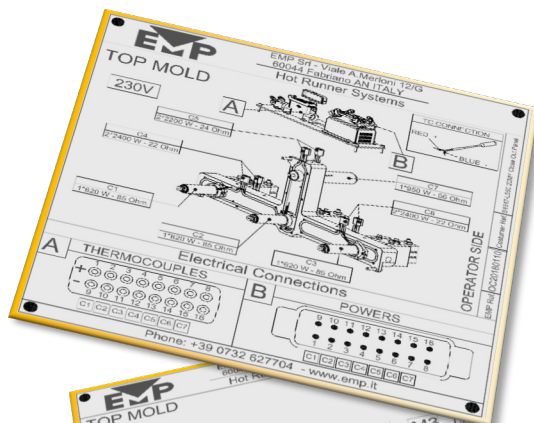
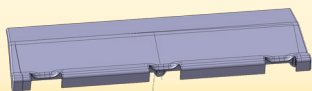

Viale A. Merloni, 12/G - 60044 FABRIANO AN - ITALY
Tel. +39 0732 627704 - e-mail: info@emp.it - website: www.emp.it





www.emp.it

info@emp.it



E.M.P. Srl

Viale A.Merloni 12/G - 60044 Fabriano Ancona ITALY
Tel. +39 0732 627704 - Fax +39 0732 627977



Hot Runner Injection Systems

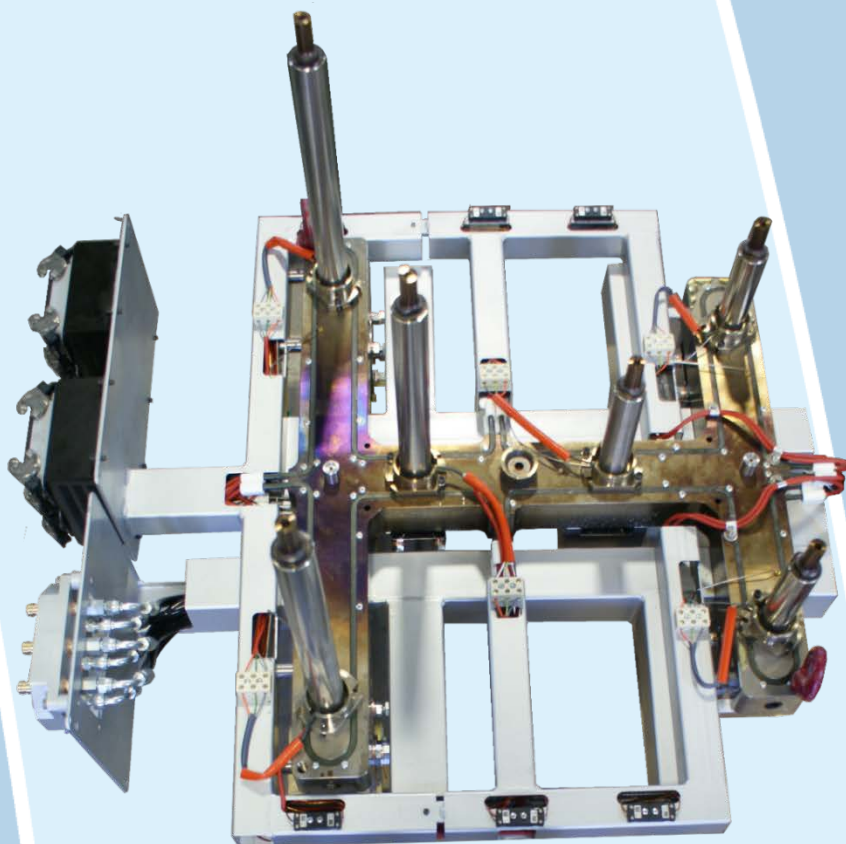

EMP SUCCESS STORY

EMP REF.: 20160265

PREWIRED HOT RUNNER

MOULDING MATERIAL: ASA

PART WEIGHT: 41 g.

OPTIONS: NOZZLES SCREWED TO THE MANIFOLD

**FAST
INSTALLATION**

**Customer
FULLY SATISFIED**

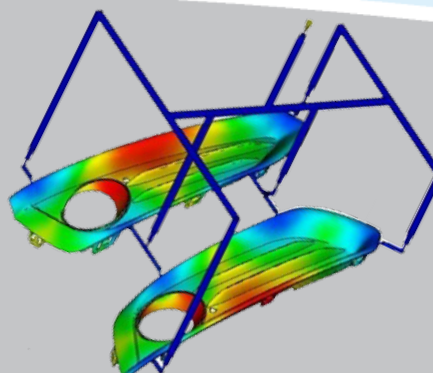



www.emp.it

info@emp.it



E.M.P. Srl

Viale A.Merloni 12/G - 60044 Fabriano Ancona ITALY - Tel. +39 0732 627704 - Fax +39 0732 627977

Hot Runner Injection Systems

AUTOMOTIVE



EMP REF.: 20150085

TECHNICAL APPLICATION

FIELD: AUTOMOTIVE

MOULDED PART: AUTOMOTIVE COMPONENT

MOULDING MATERIAL: ASA-PA

PART WEIGHT: 327 cm3

GATES: 3

OPTIONS: PRE-WIRED SYSTEM + HOT HALF

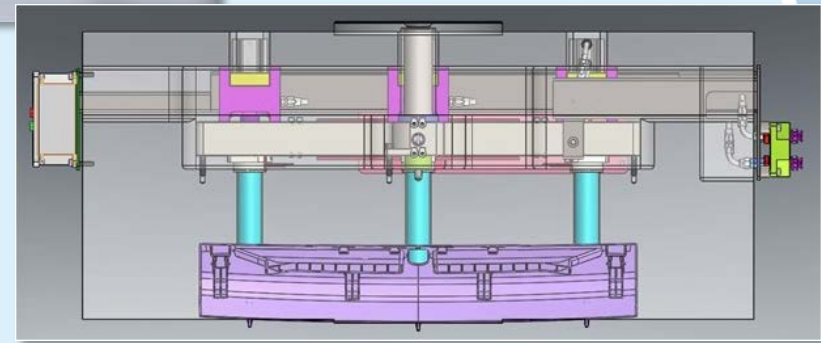
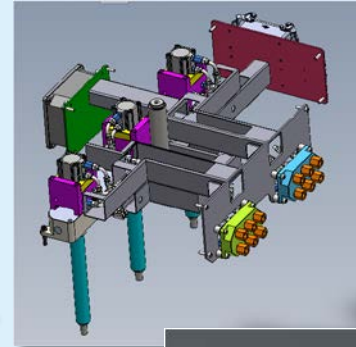
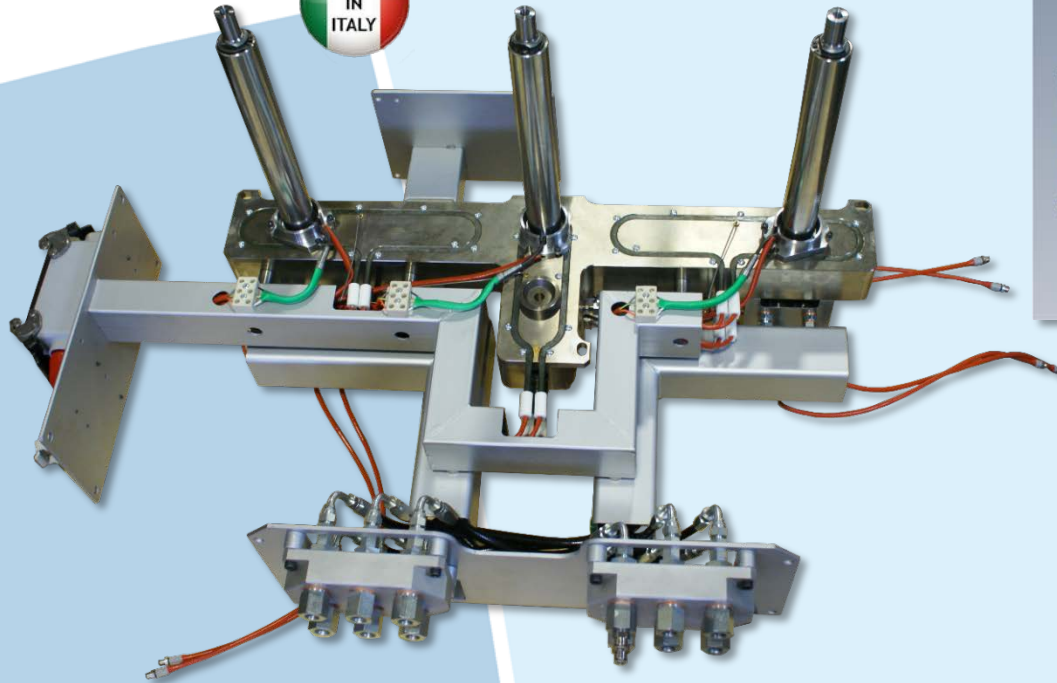

EMP SUCCESS STORY



www.emp.it

info@emp.it



E.M.P. Srl

Viale A.Merloni 12/G - 60044 Fabriano Ancona ITALY - Tel. +39 0732 627704 - Fax +39 0732 627977

Hot Runner Injection Systems

AUTOMOTIVE



EMP REF.: 20140677

TECHNICAL APPLICATION

PRE-WIRED INJECTION SYSTEM

- 4 injection point Pneumatic Sequential
- Hydraulic and cooling system
- Support panels
- Electrical panel with LED indicators

MOULDED PART:

AUTOMOTIVE COMPONENT

MOULDING MATERIAL: PC+ABS

PART WEIGHT: 235 + 191 cm3

GATES: 4

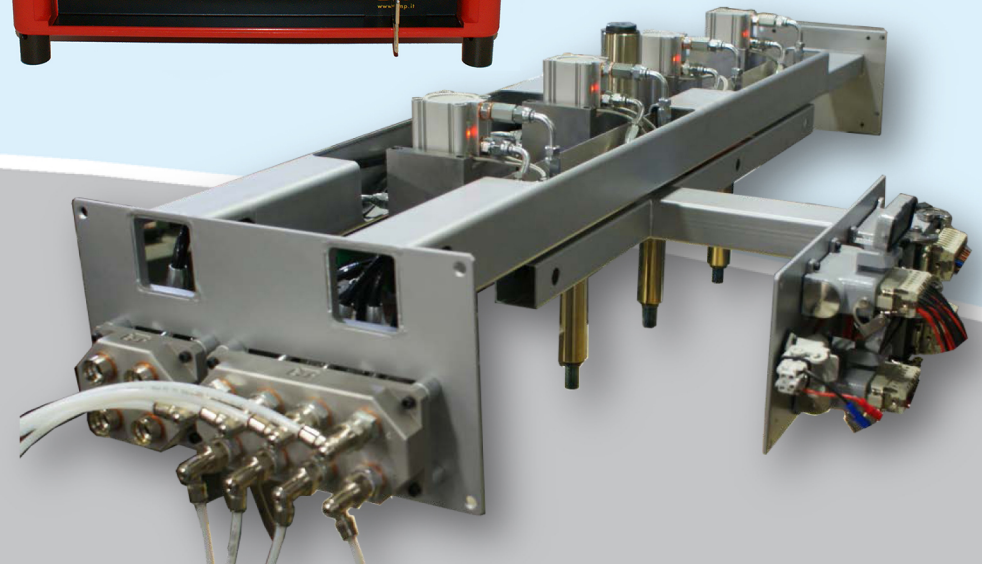
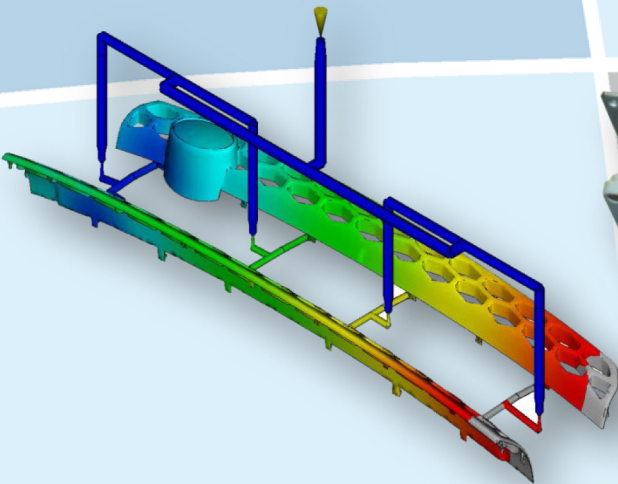
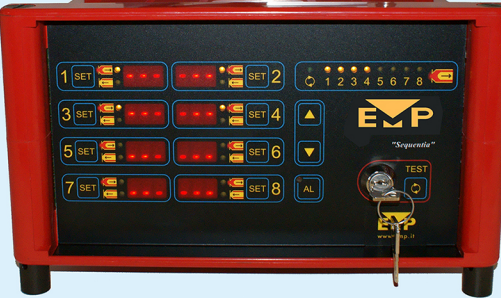
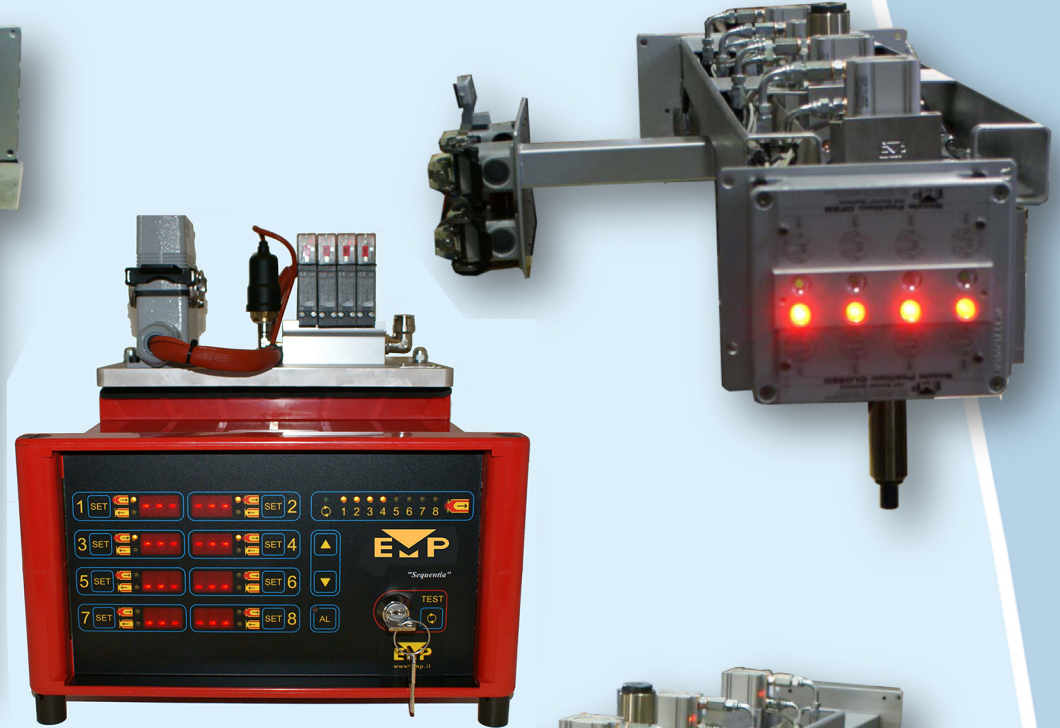
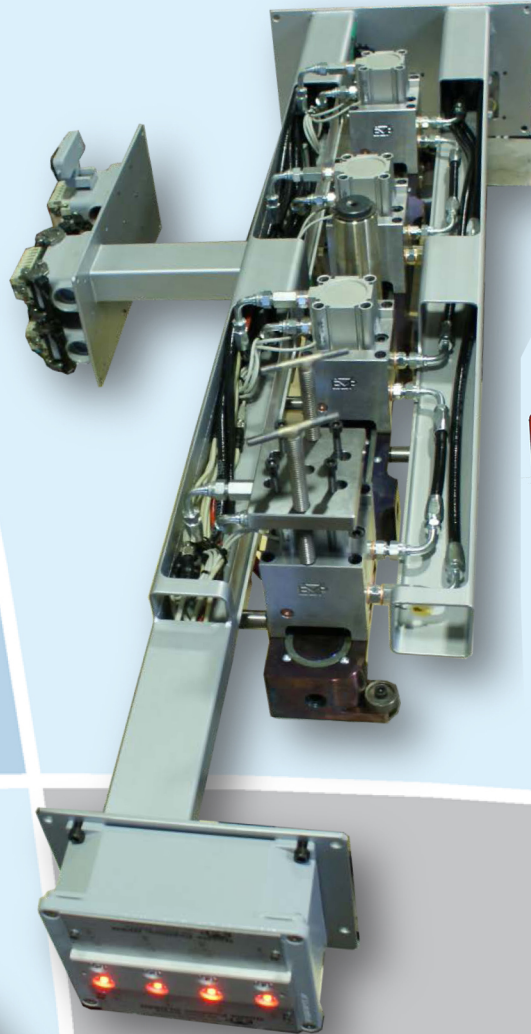

EMP SUCCESS STORY



www.emp.it

info@emp.it



E.M.P. Srl

Viale A.Merloni 12/G - 60044 Fabriano Ancona ITALY - Tel. +39 0732 627704 - Fax +39 0732 627977

Hot Runner Injection Systems

AUTOMOTIVE



EMP REF.: 20140676

TECHNICAL APPLICATION

PRE-WIRED INJECTION SYSTEM

MOULDED PART:

AUTOMOTIVE COMPONENT

MOULDING MATERIAL: PC+ABS

PART WEIGHT: 713 cm3

GATES: 6

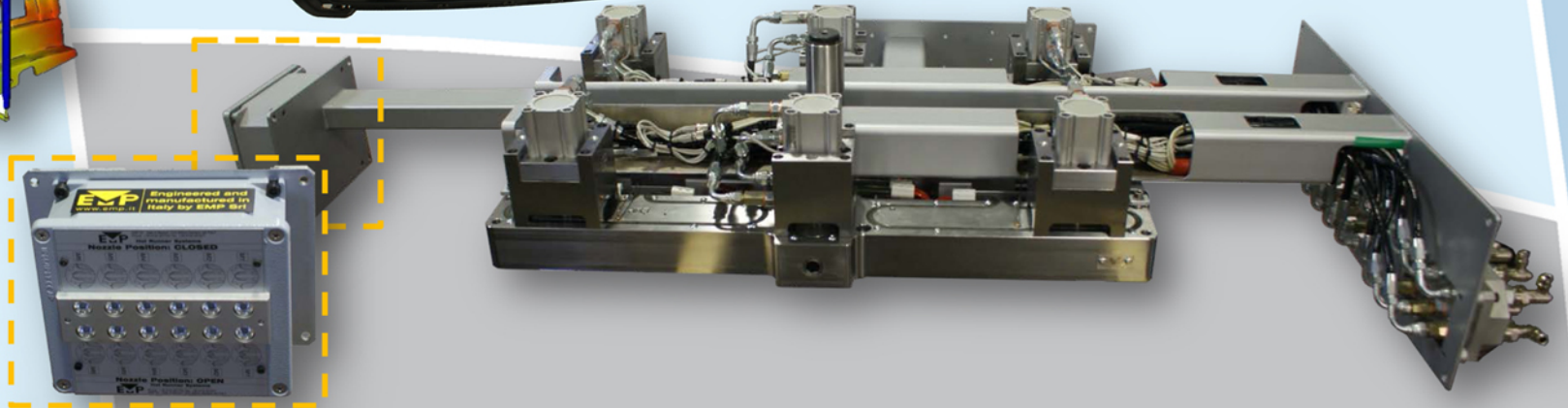
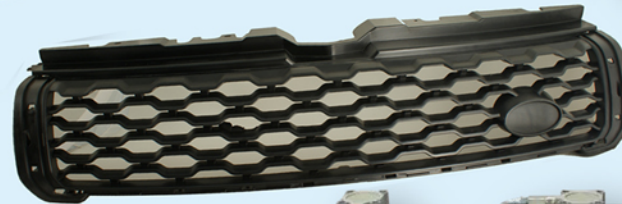
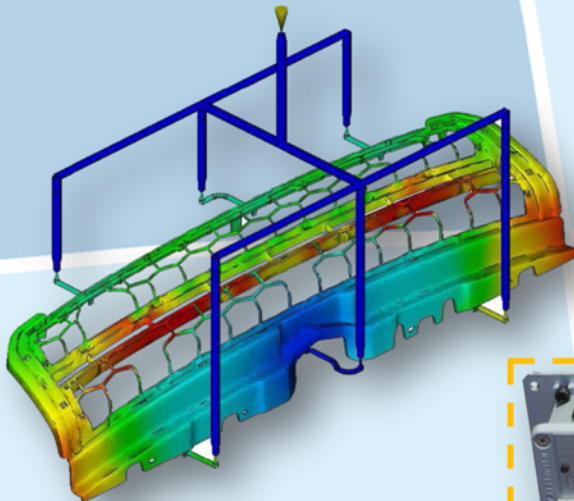
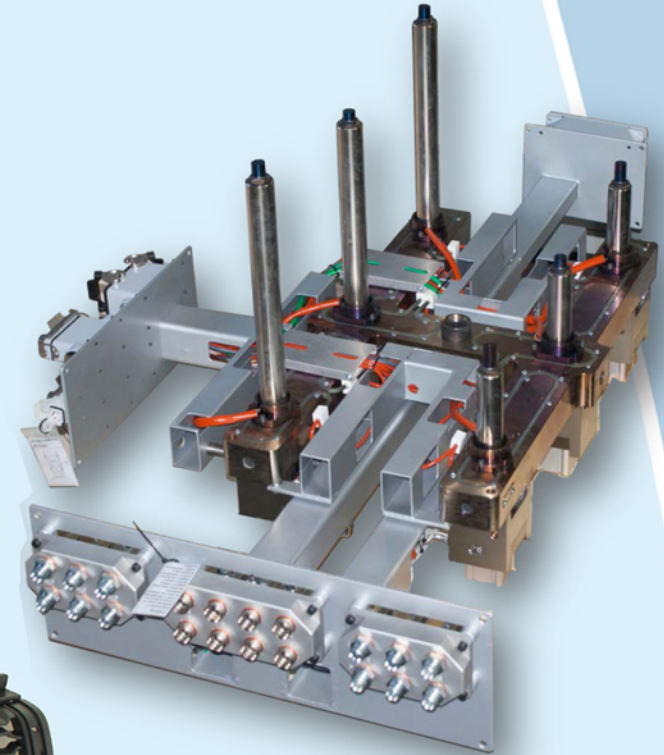
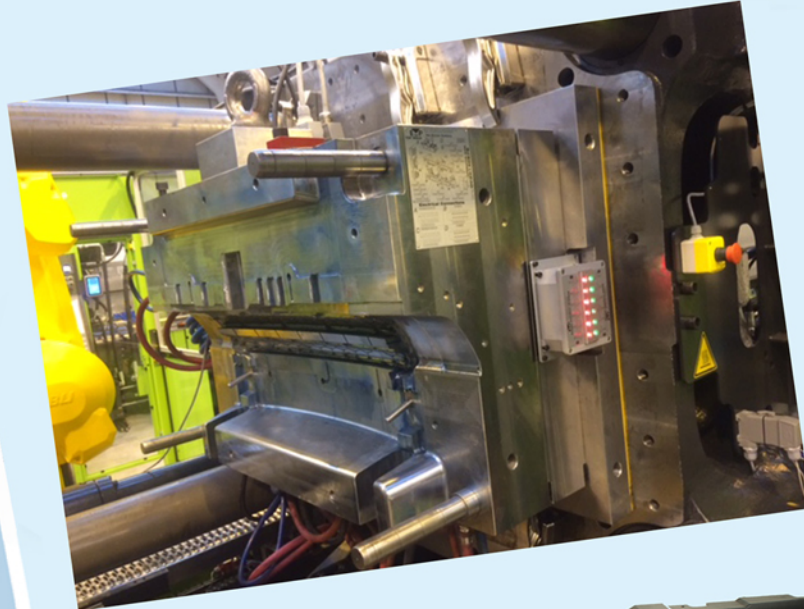

EMP SUCCESS STORY



www.emp.it

info@emp.it



E.M.P. Srl

Viale A.Merloni 12/G - 60044 Fabriano Ancona ITALY - Tel. +39 0732 627704 - Fax +39 0732 627977

Hot Runner Injection Systems

AUTOMOTIVE



EMP REF.: 20140667

TECHNICAL APPLICATION

PRE-WIRED INJECTION SYSTEM

MOULDED PART:

AUTOMOTIVE COMPONENT

MOULDING MATERIAL: PC+ABS

PART WEIGHT: 65 cm3

GATES: 3

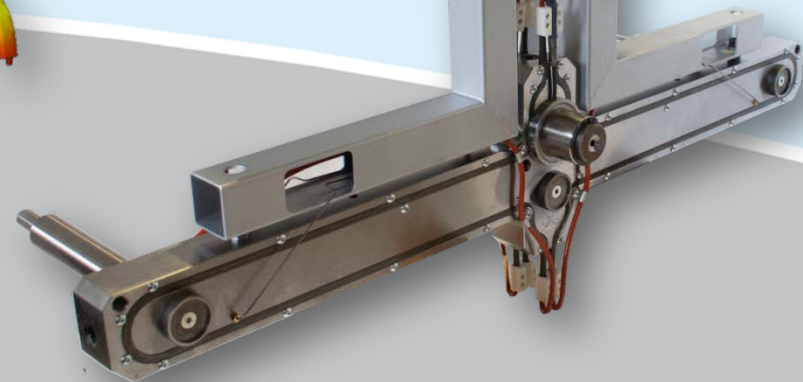
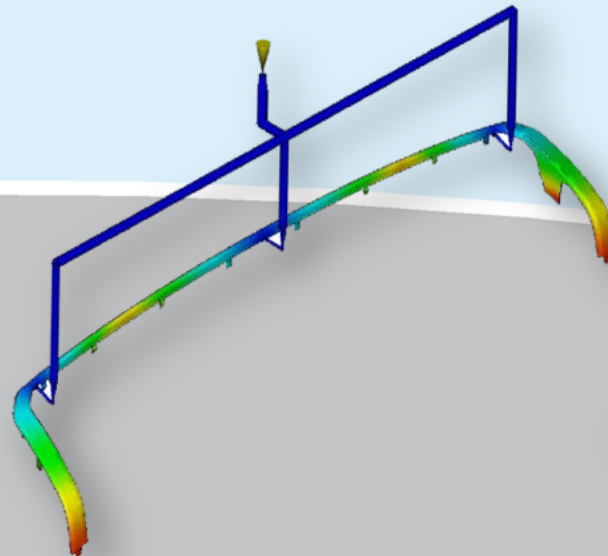
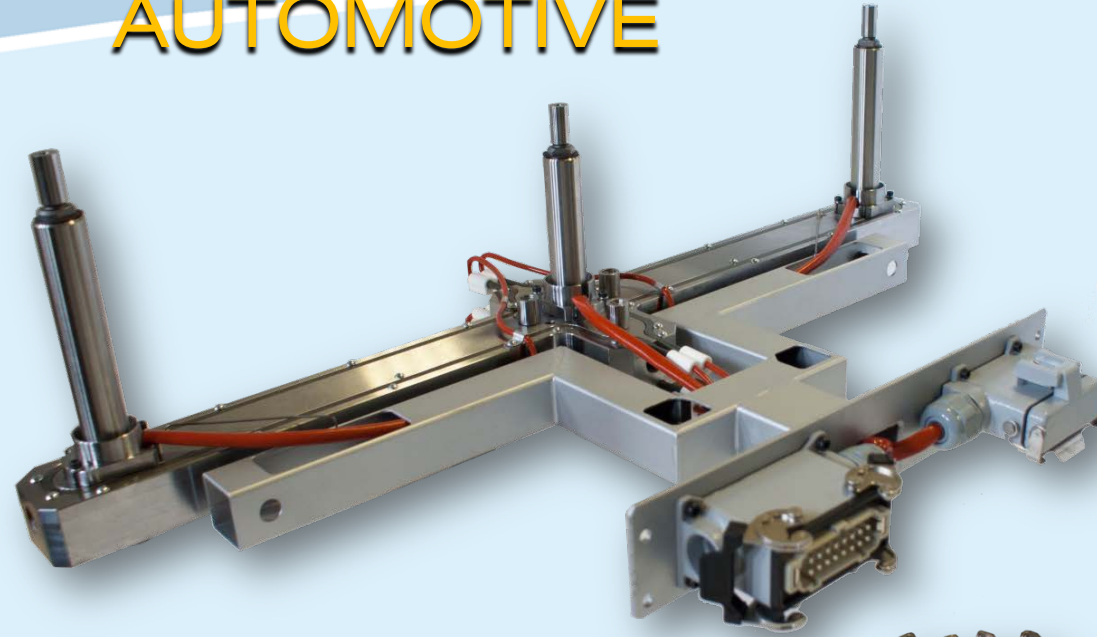

**FAST
INSTALLATION**

**Customer
FULLY SATISFIED**

EMP SUCCESS STORY



www.emp.it

info@emp.it



E.M.P. Srl

Viale A.Merloni 12/G - 60044 Fabriano Ancona ITALY - Tel. +39 0732 627704 - Fax +39 0732 627977

Hot Runner Injection Systems

AUTOMOTIVE



EMP REF.: 20140623

TECHNICAL APPLICATION

PRE-WIRED INJECTION SYSTEM

- 6 Injection point Sequential
- Hydraulic and cooling system panels
- Electrical panel with LED indicators

MOULDED PART:

AUTOMOTIVE COMPONENT

MOULDING MATERIAL: PP+30% TALC

PART WEIGHT: 370+292 cm3

GATES: 6

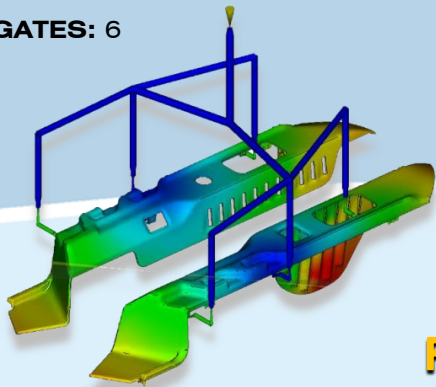
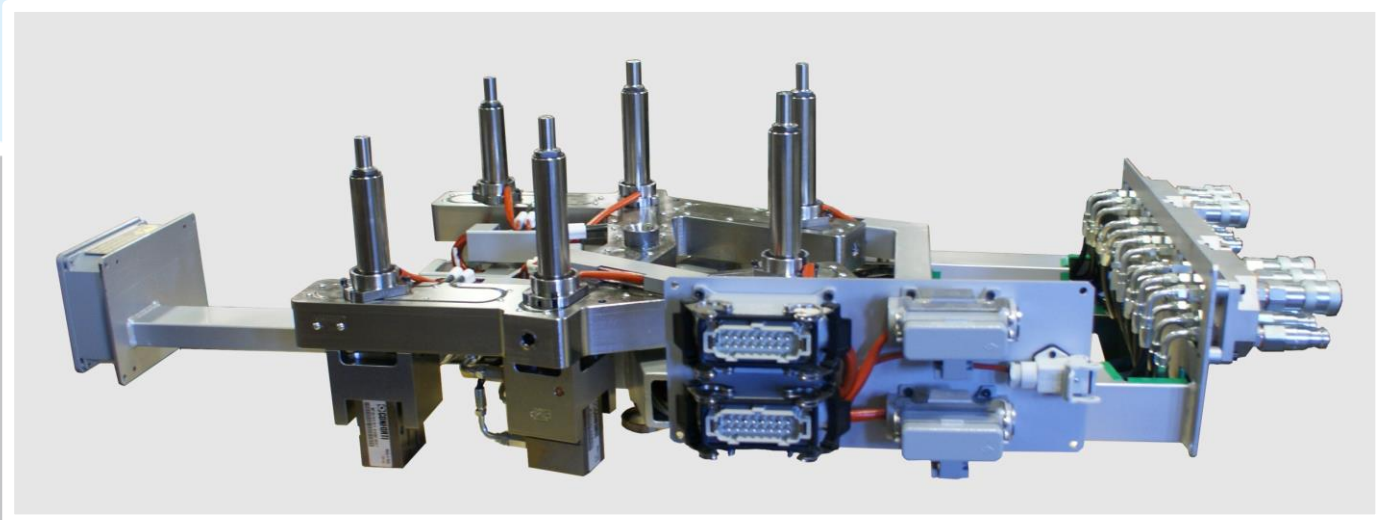
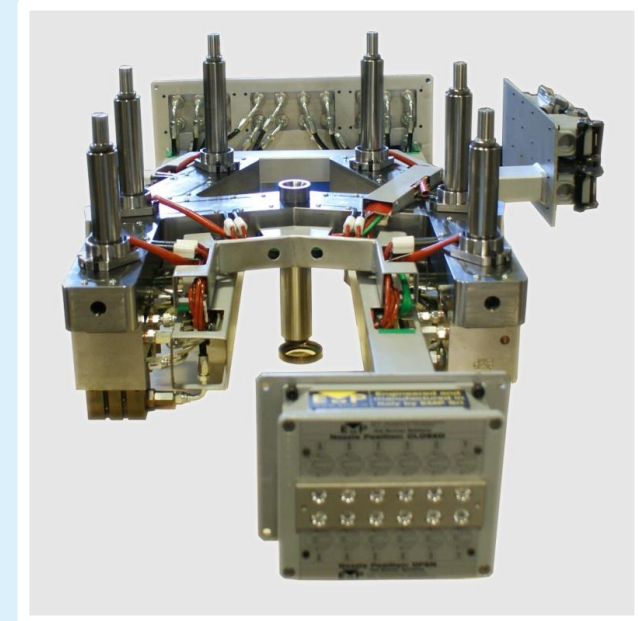
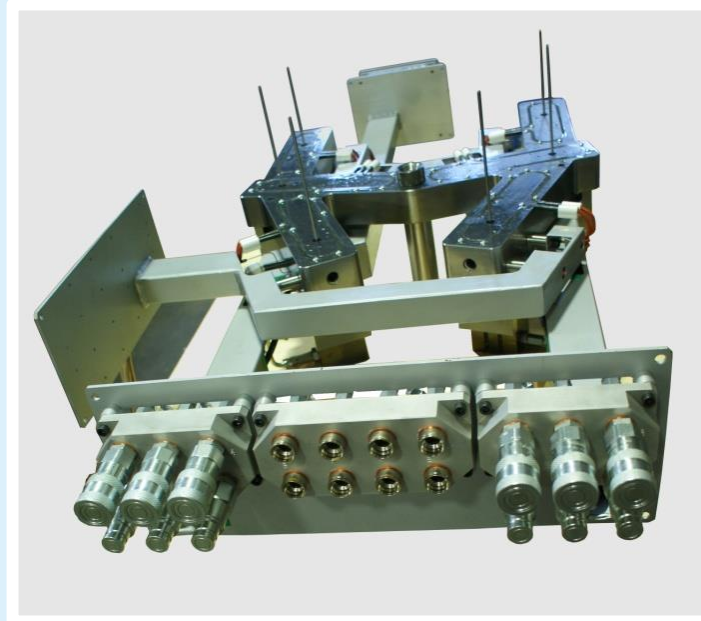

FAST INSTALLATION

Customer FULLY SATISFIED

EMP SUCCESS STORY



www.emp.it

info@emp.it



E.M.P. Srl

Viale A.Merloni 12/G - 60044 Fabriano Ancona ITALY - Tel. +39 0732 627704 - Fax +39 0732 627977

Hot Runner Injection Systems

AUTOMOTIVE



EMP REF.: 20140622

TECHNICAL APPLICATION

MOULDED PART:

AUTOMOTIVE COMPONENT

MOULDING MATERIAL:

PP+30% G.F.

PART WEIGHT: 1500 cm³

GATES: 6

OPTIONS:

PRE-WIRED SYSTEM

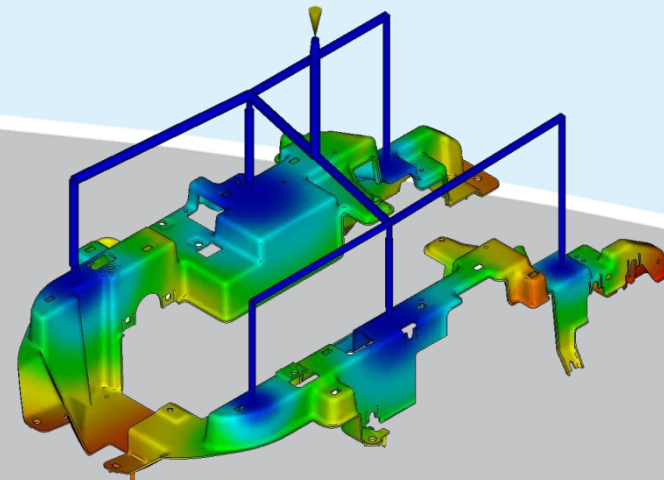
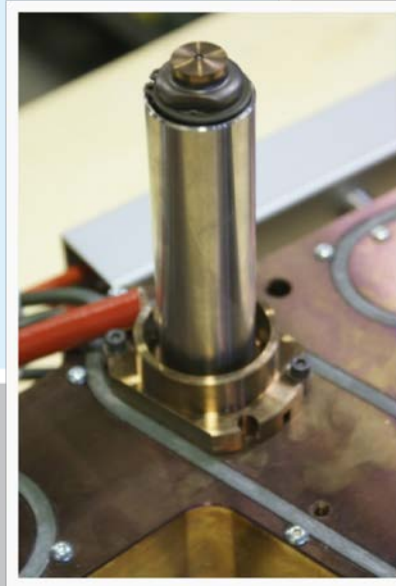
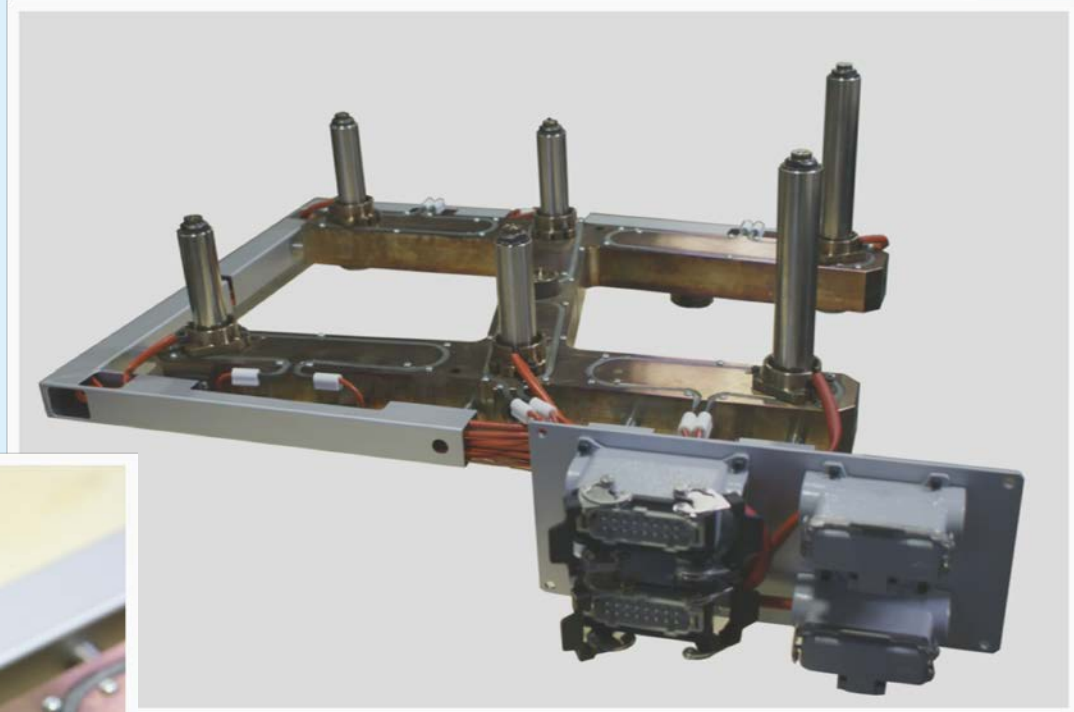

**FAST
INSTALLATION**

**Customer
FULLY SATISFIED**

EMP SUCCESS STORY



www.emp.it

info@emp.it



E.M.P. Srl

Viale A.Merloni 12/G - 60044 Fabriano Ancona ITALY - Tel. +39 0732 627704 - Fax +39 0732 627977

Hot Runner Injection Systems

AUTOMOTIVE



EMP REF.: 20140415

TECHNICAL APPLICATION

PRE-WIRED INJECTION SYSTEM

- Hydraulic and cooling system panels.
- Electrical panel with LED indicators

MOULDED PART:

AUTOMOTIVE COMPONENT

MOULDING MATERIAL: PP

PART WEIGHT: 662 cm3

GATES: 3

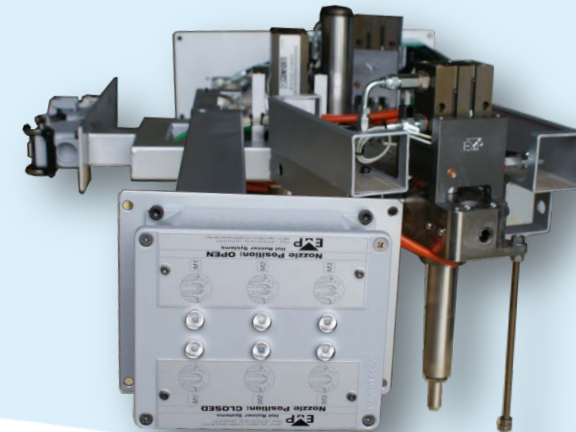
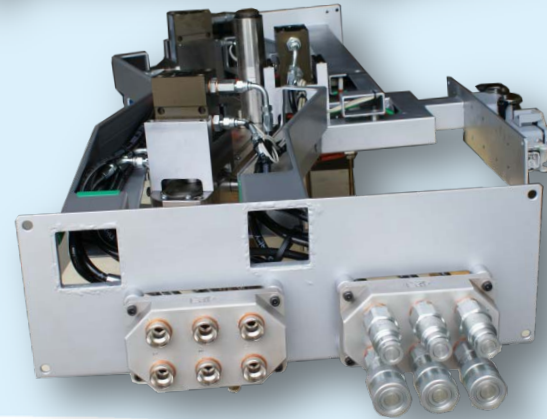
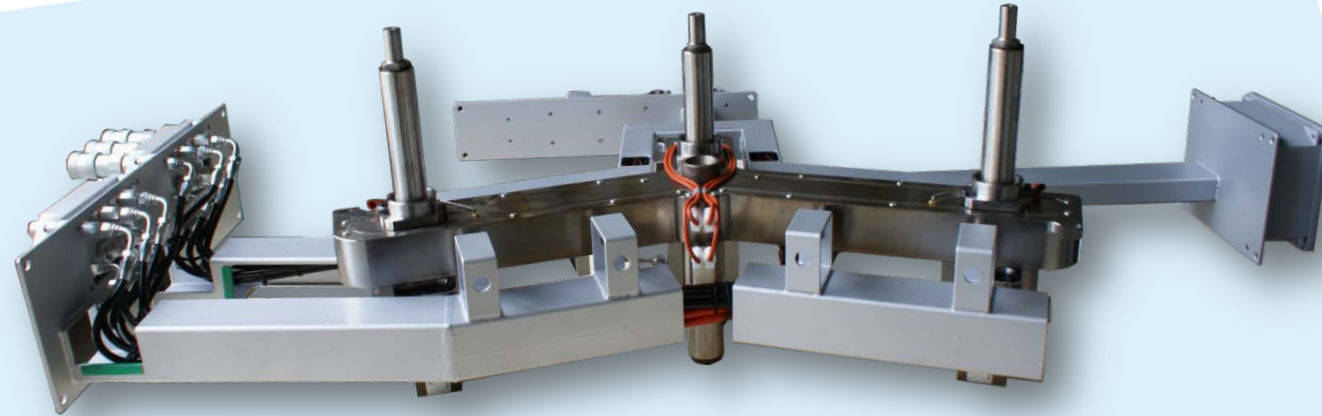

FAST INSTALLATION

Customer FULLY SATISFIED

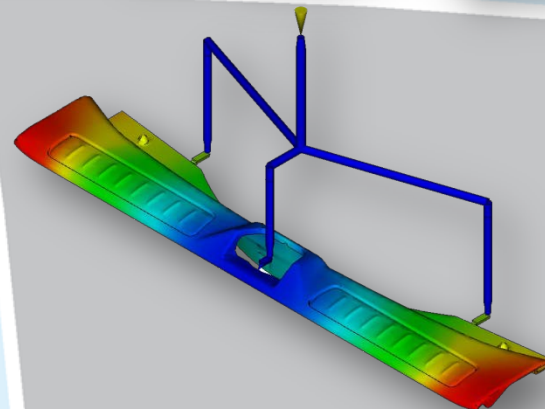

EMP SUCCESS STORY



www.emp.it

info@emp.it



E.M.P. Srl

Viale A.Merloni 12/G - 60044 Fabriano Ancona ITALY - Tel. +39 0732 627704 - Fax +39 0732 627977

Hot Runner Injection Systems

AUTOMOTIVE



EMP REF.: 20140414

TECHNICAL APPLICATION

PRE-WIRED INJECTION SYSTEM

- Hydraulic and cooling system panels
- Electrical panel with LED indicators

MOULDED PART:

AUTOMOTIVE COMPONENT

MOULDING MATERIAL: PP

PART WEIGHT: 760 cm³

GATES: 5

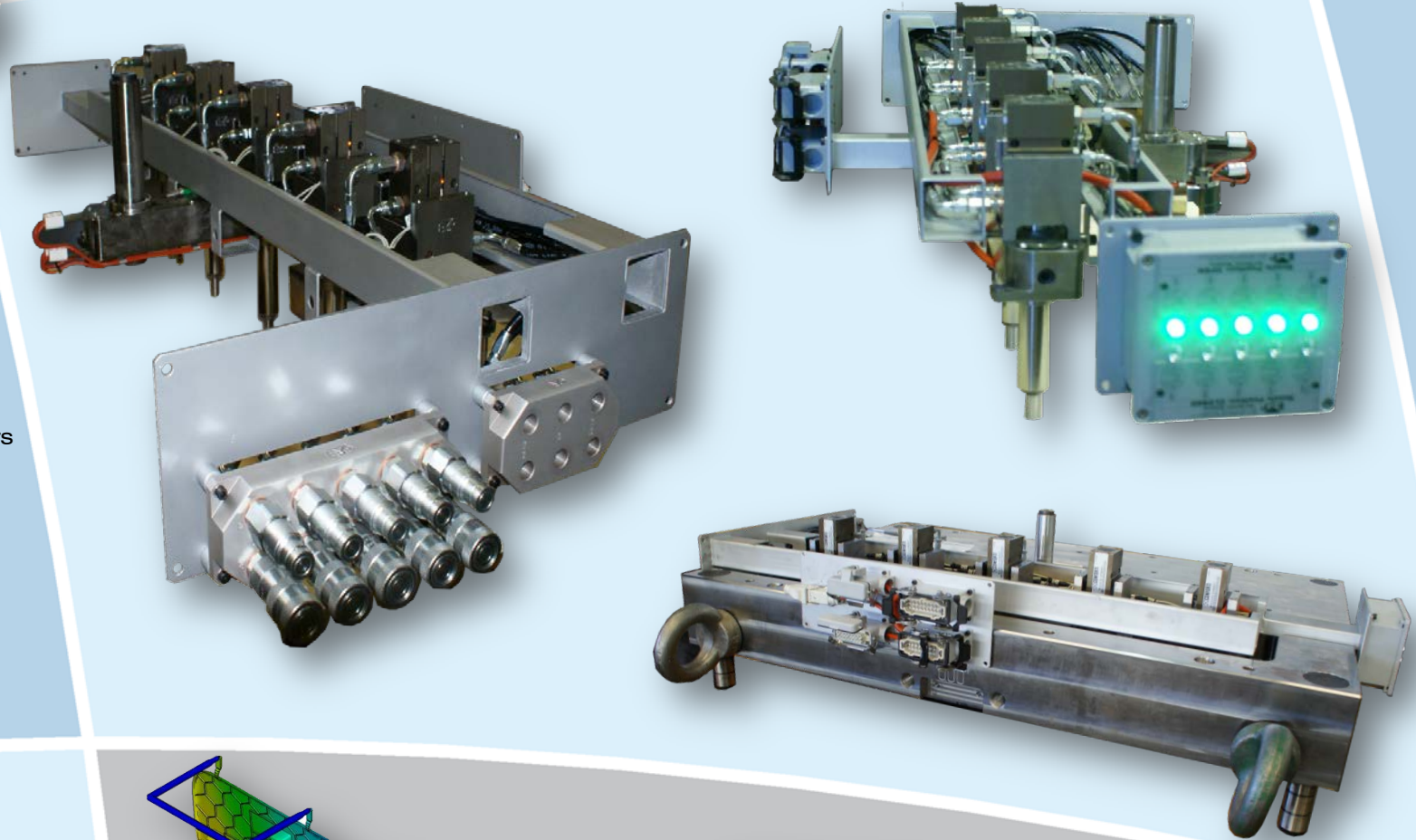

EMP SUCCESS STORY

FAST INSTALLATION

Customer FULLY SATISFIED

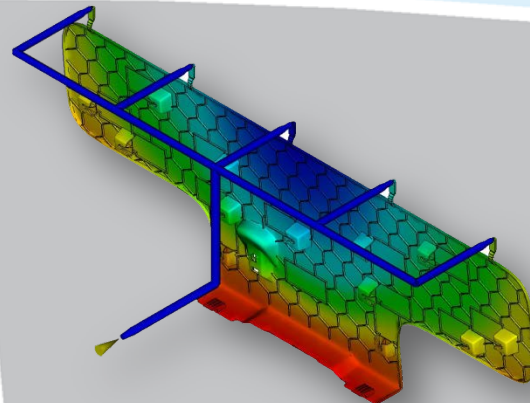

Product: S4268-FK-47022-A-PIA-01

Material: PP + 20% Talc filler Part Volume: 580 cm³

OC20140302 System Details

5 Injection point "in line" Sequential prewired hot runner system, directly feeding on ET SERIES nozzles, fixed to the manifold, inclusive of :

- hydraulic and cooling system support panels,
- electrical panel with LED nozzles position indicators
- heaters electrical plugs and sockets

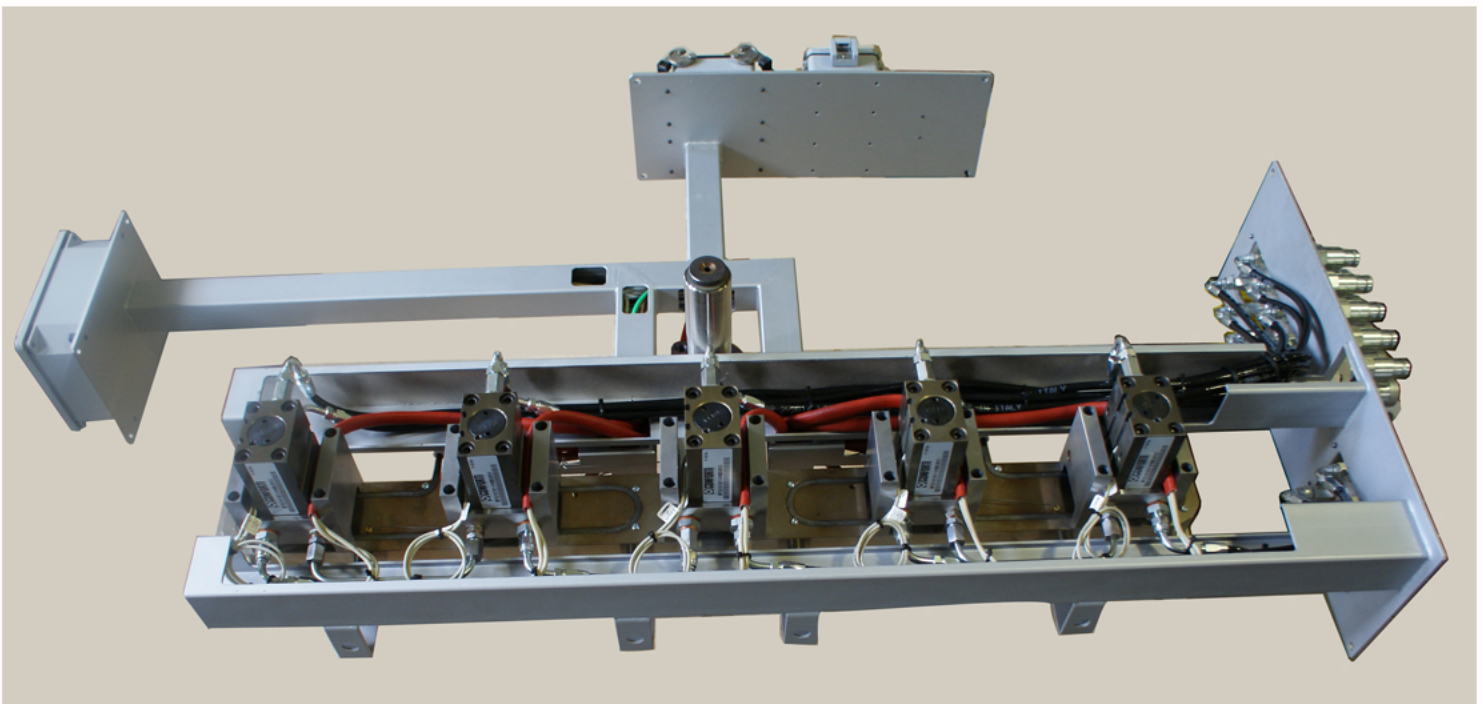

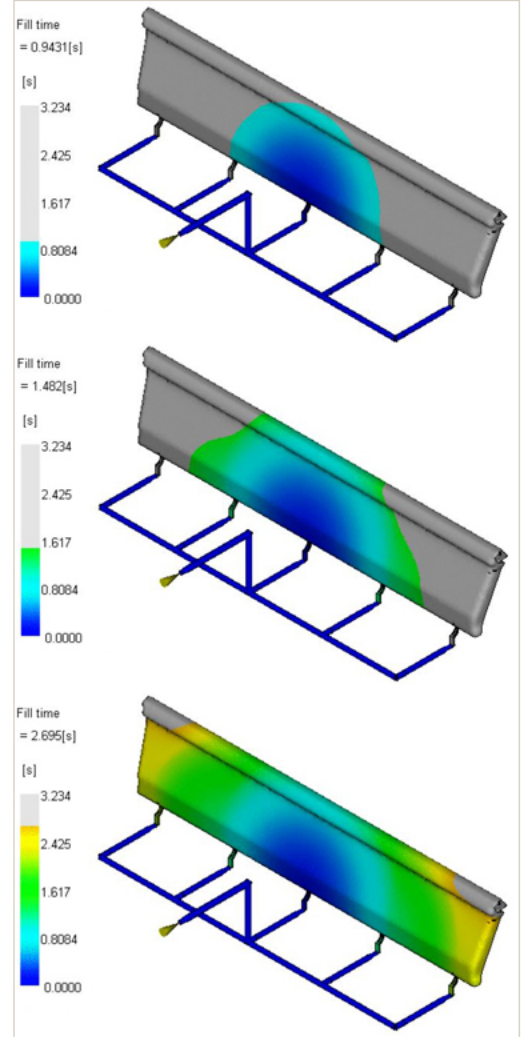
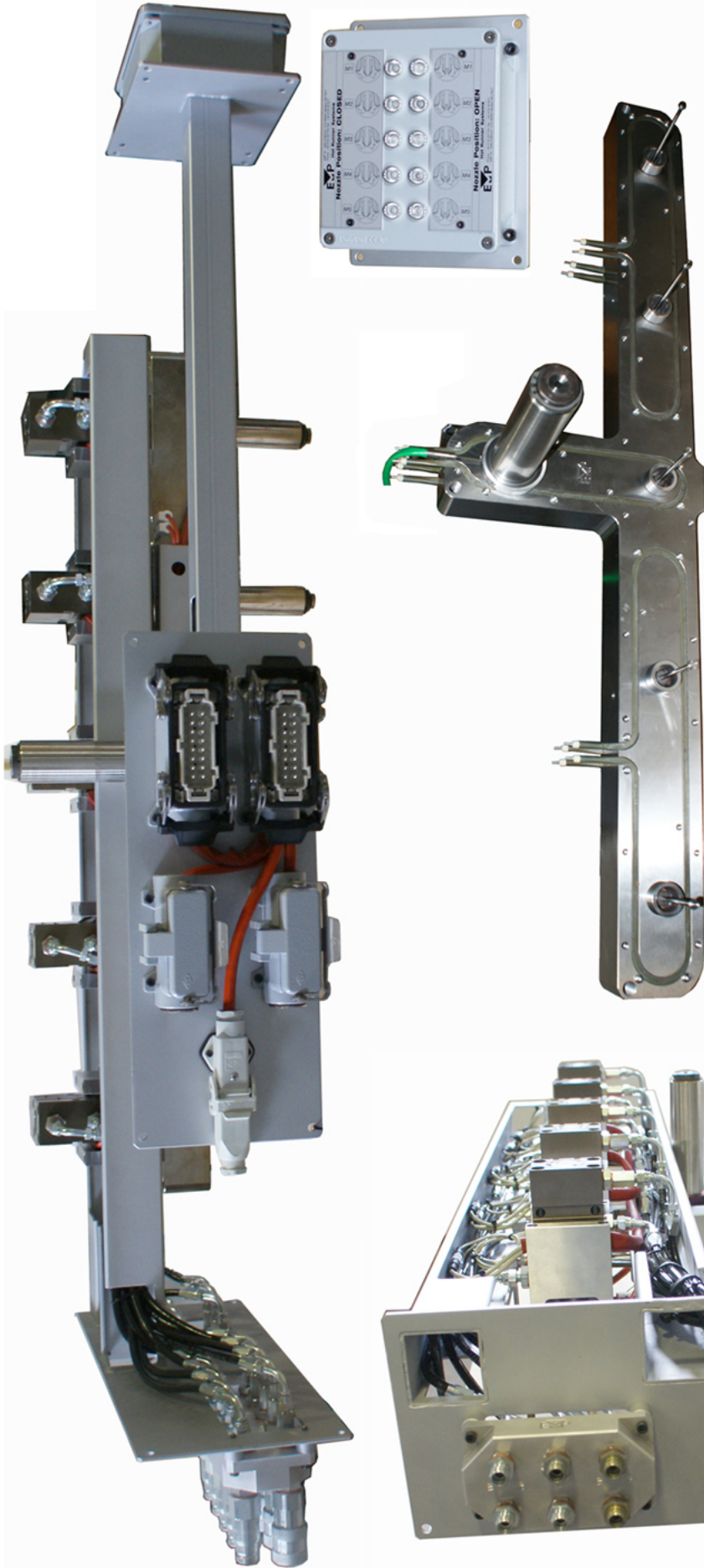



www.emp.it

info@emp.it

E.M.P. Srl

Viale A.Merloni 12/G - 60044 Fabriano Ancona ITALY
Tel. +39 0732 627704 - Fax +39 0732 627977



Hot Runner Injection Systems



AUTOMOTIVE

EMP SUCCESS STORY

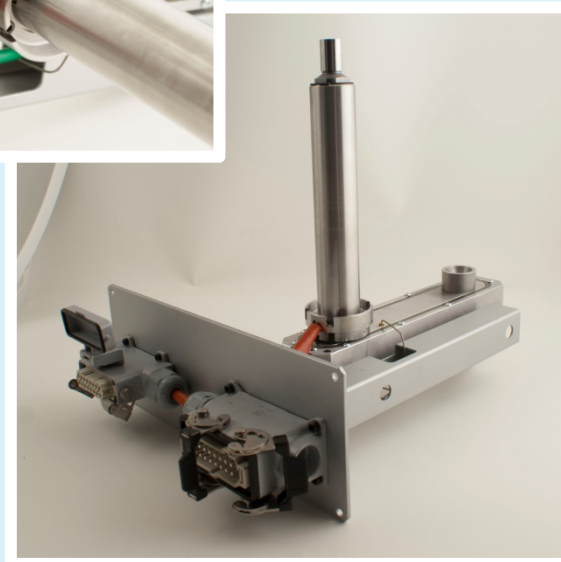
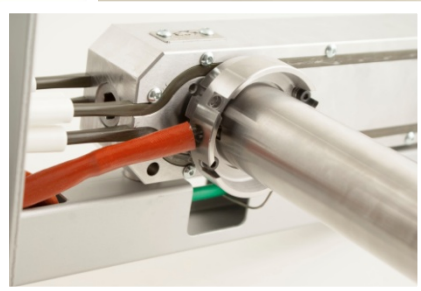

EMP REF.: 20140119

TECHNICAL APPLICATION

FIELD: AUTOMOTIVE

MOULDED PART: AUTOMOTIVE COMPONENT

MOULDING MATERIAL: PP+20% G.F.

PART WEIGHT: 1,2 Kg

GATES: 1

OPTIONS: PRE-WIRED SYSTEM

**FAST
INSTALLATION**

**Customer
FULLY SATISFIED**

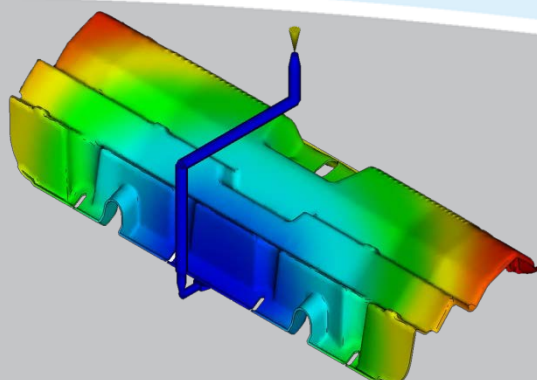



www.emp.it

info@emp.it

E.M.P. Srl

Viale A.Merloni 12/G - 60044 Fabriano Ancona ITALY
Tel. +39 0732 627704 - Fax +39 0732 627977



Hot Runner Injection Systems



AUTOMOTIVE

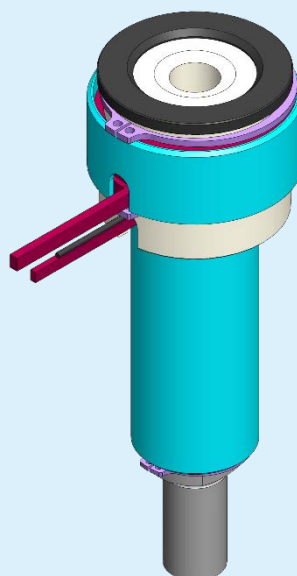

EMP SUCCESS STORY

EMP REF.: 20130927

MATERIAL: ASA UV - Starex WR93301

PART WEIGHT: 2 x 80 g.

**OBTAINED WITH HEATED HEAD NOZZLE
INJECTING ON A SPRUE**

**FAST
INSTALLATION**

**Customer
FULLY SATISFIED**

Hot-Half Package comprising: Six point balanced Hot Runner System

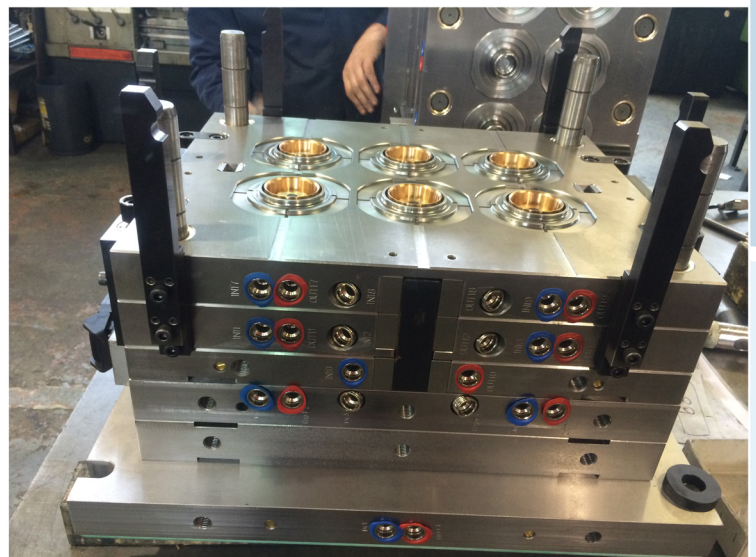
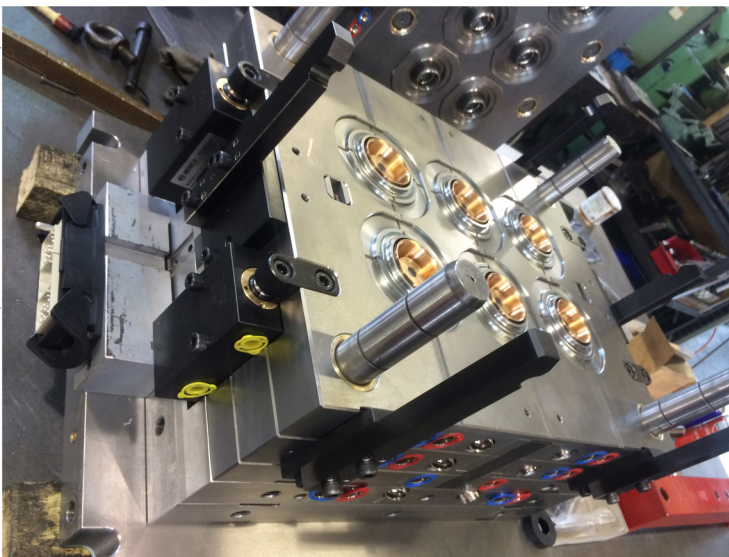
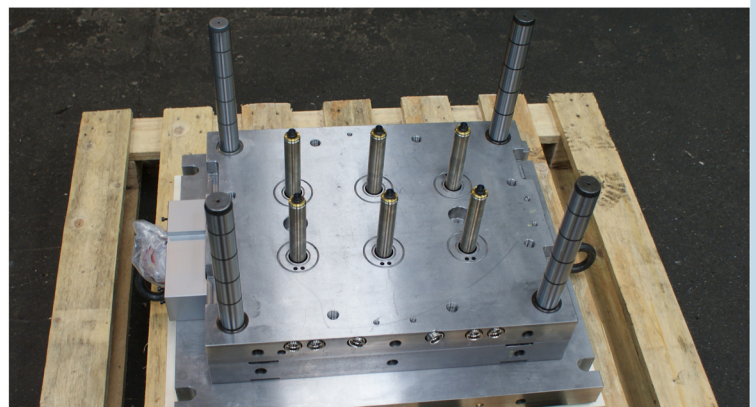
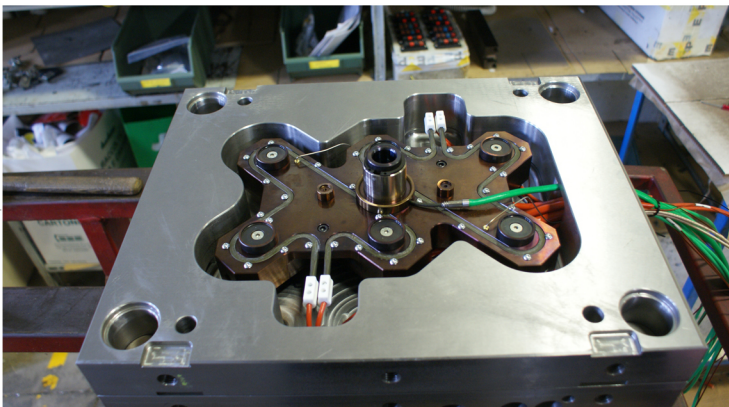
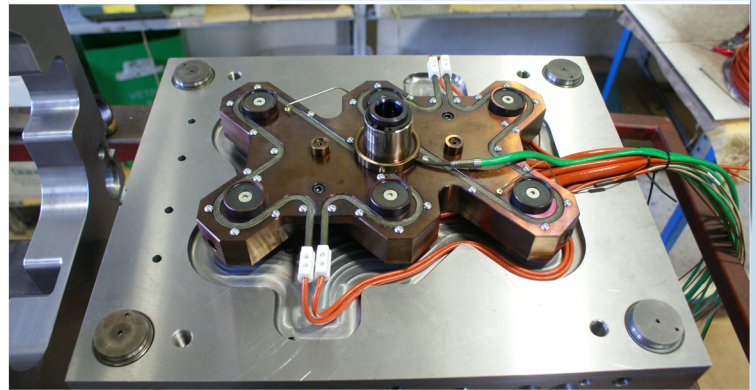
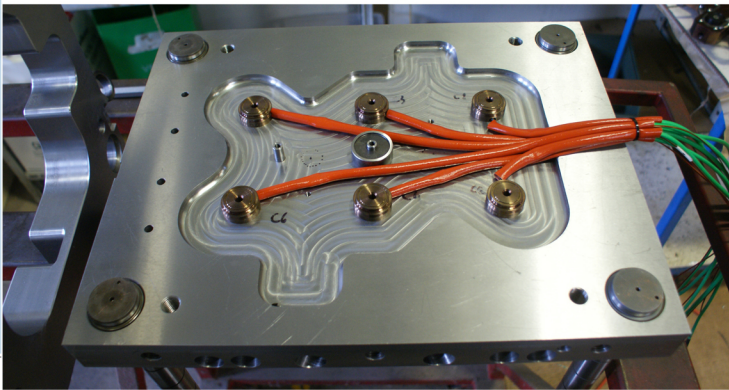



www.emp.it

info@emp.it

E.M.P. Srl

Viale A.Merloni 12/G - 60044 Fabriano Ancona ITALY
Tel. +39 0732 627704 - Fax +39 0732 627977



Hot Runner Injection Systems



AUTOMOTIVE

EMP SUCCESS STORY



EMP REF.: 20130798

TECHNICAL APPLICATION

FIELD: AUTOMOTIVE

MOULDED PART: AUTOMOTIVE COMPONENT

MOULDING MATERIAL: PP+20% TALC

PART WEIGHT: 346 cm3

GATES: 1

OPTIONS: PRE-WIRED SYSTEM

**FAST
INSTALLATION**

**Customer
FULLY SATISFIED**

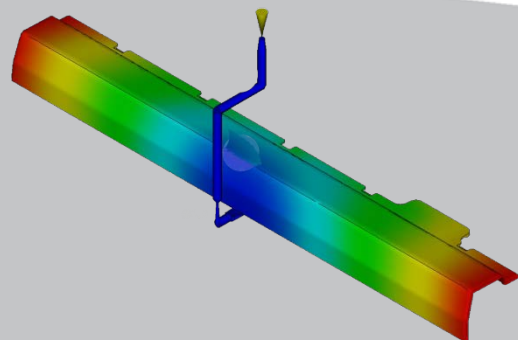



www.emp.it

info@emp.it

E.M.P. Srl

Viale A.Merloni 12/G - 60044 Fabriano Ancona ITALY
Tel. +39 0732 627704 - Fax +39 0732 627977

Hot Runner Injection Systems



AUTOMOTIVE

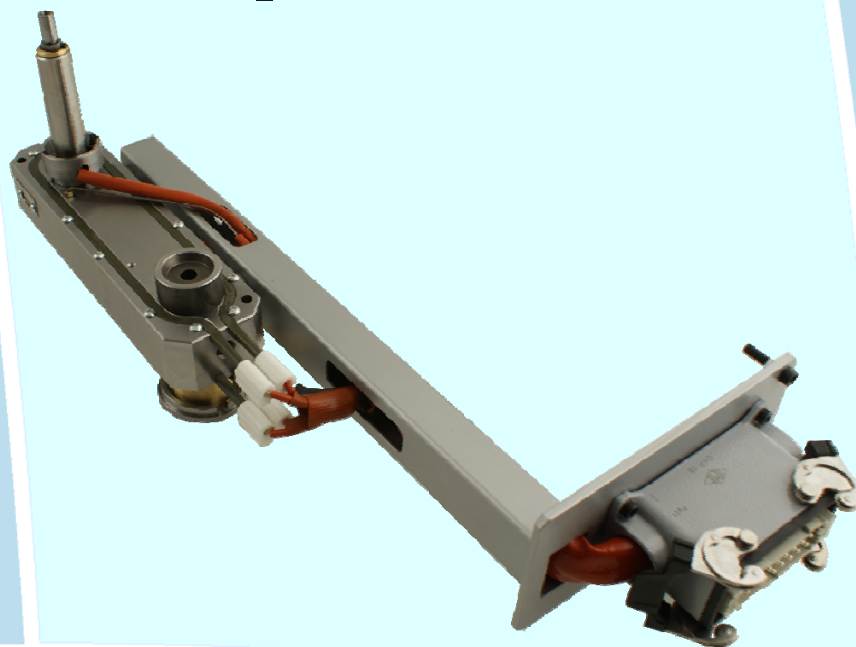
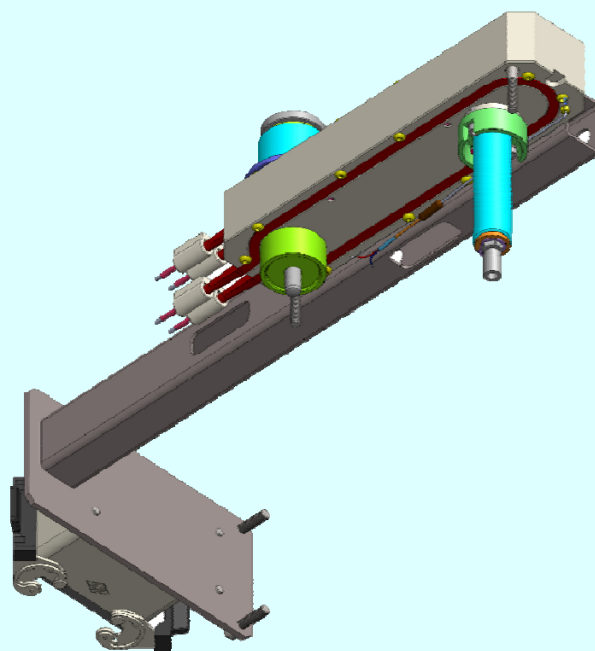

EMP SUCCESS STORY

FAST INSTALLATION

**Customer
FULLY SATISFIED**

EMP REF.: 20120790

PART: BEZEL 332,734

MATERIAL: PA + 30% GF

PART WEIGHT: 90 g.